

## **The Intermediate Effect of the Adoption of Electronic Banking Services between the Word of Mouth and the Quality of Banking Services**

**Dr. Anber Abraheem Shlash Mohammad**  
Associate Professor  
Marketing Department  
Administrative and Financial Science Faculty  
Petra University  
Jordan  
E-mail: mohammad197119@yahoo.com

**Dr. Khaled Atallah Al-Tarawneh**  
Assistant Professor  
Marketing Department  
Administrative and Financial Sciences Faculty  
Petra University  
Jordan  
E-mail: kaltarawneh@uop.edu.jo

### **Abstract**

*This study aimed to test the impact of the use of the word of mouth on the quality of banking services through the adoption of electronic banking services as an intermediary variable in commercial banks in Jordan. The study sample consisted of 265 respondents who were selected from dealers with commercial banks in Jordan as an appropriate sample. The questionnaire was used as a tool for data collection; a number of statistical methods have been used including regression, simple arithmetic averages, the normal distribution test and the structural equation. The results indicated:*

- 1- that the level of practicing word of mouth from the viewpoint of the respondents is medium.*
- 2- that the level of banking services quality in the commercial banks in Jordan from the perspective of the respondents is high.*
- 3- that the level of adoption of electronic banking services in the commercial banks in Jordan is average from the viewpoint of the respondents.*
- 4- word of mouth has a significant positive impact, as does the adoption of electronic banking services on the quality of banking services at a significance level of ( $\alpha \leq 0.05$ ).*
- 5- the presence of an indirect effect of the adoption of electronic banking services between the word of mouth and the quality of banking services at significance level of ( $\alpha \leq 0.05$ ).*

*The study recommended a set of recommendations according to the results of the study.*

**Keywords:** word of mouth, quality of banking services, the adoption of electronic banking services, commercial banks of Jordan

### **1. Introduction**

The researchers and practitioners focused in recent times on the role adopted by the departments of marketing in the commercial banks of Jordan to excel at their work and achieve marketing objectives through the use of Internet in the provision of banking services and assuring its quality to customers, in addition to the ability to explore different styles that help commercial banks achieve big satisfaction for customers. The rapid development that took place in the banking services, their diversity, and the use of the Internet to provide banking services requires special skills by bank employees so they can achieve satisfaction, first toward these services, and explore later on how to improve the quality of banking services through adopting electronic banking services.

This study is characterized by its importance, especially for researching subject which still has a big gap in the marketing literature, where this study seeks to provide an indication for the managers of commercial banks operating in Jordan about the impact of word of mouth in the adoption of electronic banking services, and showing the impact of adopting electronic banking services in the quality of banking services. This study also attempts to enrich the theoretical literature on electronic banking services and the word of mouth in the quality of banking services in the Jordanian commercial banks specifically, and achieve a clear understanding among managers of Jordanian commercial banks on how to improve the quality of banking services in such a way to strengthen the loyalty of its customers. Thus this study came to identify the intermediate effects of the adoption of electronic banking services between the word of mouth and the quality of banking services.

## **2.Theoretical Framework and Previous Studies**

Word of mouth is defined as a positive or negative feedback as a result of a service exercised by the customer or a consumer, transferred to someone else (Lovelock & Wright, 2002). word of mouth is considered one of the many factors influencing consumer perception of the quality of service or product, but the problem lies in the difficulty of controlling it. This is due to the independence of the individual carrying the word because word of mouth is not paid, and the reaction of the customer towards it relies on self-experience and personal experience (macular 0.2009). word of mouth carries a certain weight as a source of information, and is recognized, especially if it is not biased (Zeithmal et al., 2006). customers depend on two main sources to obtain information to help them make their decisions marketing:

- 1- non-personal sources: the information received unintentionally by customers from a variety of sources, including information through television, magazines and the Internet.
- 2- Personal Sources: represented by the effects of the word of mouth from friends and coworkers. (Money et al., 1998)

Murray (1991) Has pointed out that consumers rely on word of mouth communications to reduce the perceived level of risk and uncertainty associated with the purchasing decisions of the product. word of mouth can also be considered as a promotional tool in terms of impact, being considered one of the most important assets if coupled with positive tones, and vice versa when word of mouth is of a negative tone.

Word of mouth is considered a moving advertisement so advertisers must monitor this trend, especially from customers with high satisfaction levels, which leads to cut costs and attract new customers (Lovelock et al., 2002) Communication through word of mouth is a factor in consumer perception of the quality of service or product, but the problem lies in the difficulty of controlling it. The reason for this is due to the independence of the person speaking the word, communication through word of mouth is not paid, and the reaction of the client about the word of mouth depends on expertise and personal experience, and lies in its ability to form expectations of service (Davis et al.1997)

since it's a source of information, Word of mouth communication carries certain weight, because it's recognized of being unbiased (Zeithmal, et al 2006). The client usually resorts to others to ask for advice about products and services. The spokesman of the information is called "the influencer." Also, the client usually depends on two main sources to obtain information to help in decision-making: non-personal Sources: represented by what information the client receives via television, magazines and online community sources of information. And personal sources: represented by the effects of the word of mouth from friends and co-workers (Money, et al 1998). It has been found that many of the people dealing with banks rely on the word of mouth connections to reduce the perceived level of risk and uncertainty associated with the purchase decisions of service. And in comparison with the decisions associated with the purchase of the service, the purchasers of services have high confidence in their personal information sources and bigger preference of the pre-purchase, depending on the sources of personal information. It's also concluded that the personal sources have higher effects on the purchase of services compared to the purchases of goods.

### **2.1 Quality of Banking Services**

The subject of Quality of banking services is one of the issues that topped the concerns of researchers, and has generated many studies that have addressed the subject where there were many opinions of the writers in the concept of quality of banking services, as defined by Trolle and Schwartz (2010) in four main dimensions: Banking , style of provision and customer service, physical and electronic resources and possibilities.

Parasuraman et al. (1991) introduced the gaps model, also known as model (PZB), and according to this model SERVQUAL, the quality of banking services is measured by the main dimensions which are: reliability, response time, capacity or efficiency, ease of access to the service, suaveness, contact reliability, safety, understanding of the client, and the tangible financial aspects. Below is a breakdown of each element of the previous explained dimensions of quality of banking service:

- **Reliability:** which means stability of performance, proper achievement of service better than the first time and meeting what the bank has promised to the customer, this includes: the accuracy of the accounts, files, lack of errors, providing banking services correctly, providing service in a timely manner when needed, and the consistency in the level of performance of the service.
- **Response time of workers:** represented by the desire and willingness of the bank staff to provide service and assistance to customers and respond to their queries, the speed of the performance of the service, and the immediate response to the request of the client.
- **Capacity:** which represents the bank staff's possession of the skills and knowledge necessary to perform the service, and the spirit of communication and understanding customers.
- **Ease of access to the service:** This includes the ease of communication and access to the service by the client, the shortness of the waiting period to obtain the service, being convenient with the working hours of the client, and the availability of a sufficient number of outlets to get the service.
- **Suaveness:** bank's employees, especially those who have contact with customers, must portray the required respect and be good-looking, enjoy the spirit of friendship, affection and respect for customers.
- **Contact:** requires providing customers with the information in the language they understand, and provide necessary clarifications and explanation about the nature and cost of the service, the advantages of the service, and possible alternatives.
- **Credibility:** the bank taking into account integrity and honesty in dealing with customers, which generates trust between the parties because the banking business is based on trust.
- **Security:** This reflects the absence of uncertainty and risk in transactions with the Bank, including physical security, financial and confidentiality of transactions.
- **Knowledge and understanding of the client:** means making the effort to understand the client's needs and special needs, individual attention to the customer, knowing the long-term clients of the bank, and providing advice, counseling and guidance.
- **Tangible financial aspects:** includes financial facilitations used at work starting from the outside appearance of the bank to preparation from inside, the devices used and the methods used in delivering the service.

As the bank manages to control these dimensions, it can provide services with high quality, develop services and achieve competitive advantage. The quality of banking services is linked and dependent on the needs and expectations of customers, if the service was provided in accordance with the needs and expectations of customers or surpassed them, it is said that the service is characterized by quality (Irons 2001).

The quality of service is considered a measure of the degree to which the level of service grows to meet customers' expectations, and that the quality perceived by the customer of the service is the difference between customer expectations of the dimensions of quality of service and the actual performance, which reflects the availability of these dimensions already. Also, providing the quality of service that customers continuously want is a fundamental goal of the bank and reaps some positive benefits such as increased profits, growth, continuity in the market and competitiveness.

The famous gaps model presented by Parasuraman et al. (1985) included several types of quality, namely:

- A. Expected Quality: The client's expectations for the level of quality of service, and depends on the client's needs, previous experience, culture and connection to others.
- B. Quality perceived by the administration: The extent to which the bank recognizes the needs and expectations of its customers, as well as providing banking services with specifications realized to be at the level that satisfies the customer.
- C. Promoted Quality: information about the service, its properties and what the bank pledged to present, which is transferred to customers through a marketing mix of advertisements, along with personal promotions and Publications

- D. The actual service provided to the customer: the bank's staff delivery of service and presentation in accordance with the specifications set by the bank, which undoubtedly depend on the skill of workers, good composition and training. The service provided and its quality may vary from one bank to another and in the same bank from worker to another, and may vary per worker based on his condition, psyche, and the extent of exhaustion at work.
- E. Perceived service: the customer's estimate of the actual service (the actual service provided to him), which largely depends on the extent of the customer's expectation, for example, if the actual banking service is offered to the customer in 10 minutes, and it was expected to be obtained at a longer period of time (15 minutes, for example), the customer will perceive the banking service as a high-quality, but in the opposite case, the customer will perceive the banking service as low-quality.

So the quality of banking services is considered a measure of the degree in which the actual level of service provided to customers meets their expectations, and therefore the provision of service of distinct quality means matching the level of quality with the actual customer expectations, because the concept of quality of banking services lies in the extent to which the actual services provided matches customer's expectations of the dimensions of quality of service, and the level of actual performance, which reflects the availability of these dimensions already in the service provided to them.

## 2.2 Electronic Banking

providers of banking services head towards networks across the Internet to provide customers with many banking services without knowing who those customers are, what their needs and desires are, and what they want in a banking service provided. The traditional banking environment helps in monitoring and data gathering, with sufficient precision, the actions and reactions of customers with the bank, but the truth is that the electronic environment allows providers of Electronic banking access to vast amounts of information about the behavior of customers through the process of consumption of the service, by collection of opinions and requirements in different forms. Thus, the important question to be asked is: are providers of electronic banking services via the Internet networks able to analyze and understand the information they had obtained, and translate them into specifications for the design of the service?

The other question relates to how the electronic management of the globalization of the quality of service based on the specific needs and requirements of the customers allow the management of quality of the Banking services across these networks, develop a system to measure this quality, and facilitate the monitoring process in the electronic environment, on the grounds that the banking technology has become an important tool for ensuring the efficiency and effectiveness of the banking business, identify deviations that show the strengths and weaknesses of the performance, and thus can easily overcome problems of quality in the banking services.

It is therefore essential for the beneficiaries of these services to understand how weaknesses in the globalization of the quality of banking services across the Internet by adopting the concepts of quality management and service structures. What is quality of service from the perspective of Internet networks? The quality of service in the concept of networking is: "a set of service requirements to be met through the use of these networks during the flow transfer process, where the flow here indicates the stream packet flow from the source to the destination so that it is associated with the quality of service".

Here, the quality of service indicates the level of service measurable for network users, which can be described as the potential loss of available package and breadth (packet loss probability) bandwidth and delay from end to the other. Therefore, the quality of service is offered by the network service providers under the terms of certain agreements such as: service level agreements between network users and service providers (Kolodinsky et al., 2004). And the Delhi-Hyderabad-London (2007) define the quality of service as a theoretical technology that seeks to achieve the intelligent use of Internet through the application of bookings and measures of the quality of service for subgroups distinct from the data. As the informational definition of the quality of service has been presented by (Ivatury & Mas, 2008) where the quality of service was looked at as a set of concurrent processes, which effectively operates the widening to provide the levels of networking services with the necessary applications, as they apply unique structures for policies of the service, which extends to the establishment of serviced links and huge systems. Moreover, (Lee and Young, 2009) perceived it as one of the most important areas for the development of Internet, because the more advanced the Internet became through connections used for real-time applications, a need for better service will emerge.

Banking services through the internet represents individual services, where each client determines the kind of interaction with the bank using the internet regardless of the client's situation, nature of work, or place. Therefore, if the bank considered the internet as a long-term method to achieve strategic goals, it is necessary to focus on delivering high quality services through such networks in the framework of globalization, and thus positive quality must be maximized to guarantee customer satisfaction. Clients in the servicing industry are more sensitive to service quality and delivery, and those clients are the ones that are always in the front. Thanks to the e-commerce revolution nowadays, communication became through the interaction between information technology and self-service technology, along with the customer's awareness of the provided service through points of sale or moments of confidence that make him decide on continuing to deal with the bank or stop doing so. It is important to focus here on the quantitative aspects of service such as convenience, integrity, responsiveness, timing, and assurance. These aspects must be present at all times and by all means in electronic banking, which means they must be engraved in the design of the services.

Bank managers must monitor, regardless of their managerial levels, the level of quality in the banking services. That way, the bank will be able to compete with other banks. The managers must also understand the necessity of focusing on methods to design quality and enrich its making techniques with accuracy and precision, in harmony with the long-term measures for service quality.

According to Cracknel (2004), internet networks formed through mutual linkage of computer networks, and individual networks all over the world through cell phones, satellites and other remote communication systems (telecommunication). Due to the continuous improvement, new types of business were formed. In the field of banking services, three main types appeared (Adagunodo, 2007): first type: informational, which is the basic level of the electronic banking in the age of globalization, as the bank possesses promotional information about good and services it deals with, and so the risks of dealing with that kind of business is less.

The second type: communicative, which allows for interactions between banking systems and the client. Such an interaction can be made through email, or any other way.

The third type is: transactional, which allows clients to execute transactions using the network, and here comes the importance of service quality through internet networks. Accordingly, the features achieved by globalization of service quality of banking services through the internet fall within the following points (Anuasi, 2009): delivering banking services regardless of time and place barriers, and such work is available 24/7 anywhere in the world where networks are available, having access to banking services easily. It is also considered a low-cost method to distribute banking services or promote them, as well as expanding without opening new independent branches.

With this in mind, it is clear to us that the quality of service of electronic banking has a direct impact on enhancing the customer experience, better customer service will definitely lead to better banking operations. banks often receive requests for new services, and what can be said is that electronic processes make banking systems more acceptable, in addition to accomplishing tasks faster with enhanced customer confidence in the automated services, and the need for personal interaction between the customers and the bank decreases.

the success of the quality of electronic banking services strategy depends on important factors such as: attracting customers to this service and facilitating the deal with the bank, focusing on the needs and desires of customers and restructuring the banking operations to be in line with the customer's perspective, as well as expanding the network of communications and banking information, and gaining customer loyalty (customer loyalty) which is considered an important factor of success in electronic banking (Ab, 2008). Accordingly (Arens, 2010) indicated factors by which to measure the quality of electronic banking services, including the following:

- A. (service availability) the ability of users to connect with networks at any time.
- B. Delay: any time it takes to move the service over the network from one end to the other.
- C. (delay jitter): any change in the delay, which is accompanied by similar packets, which follow the same router over the network.
- D. Completion rate (processing capacity) (throughput) rate of any incoming packets over the network.
- E. Packet loss rate: rate of any lost packets during the work on the network.

### 2.3 Previous Studies

Abdullat (2006) had a study to identify obstacles to the expansion to customers in electronic banking in Jordan by means of ATM, POS, online banks and telephone banking. The study found that the percentage of those who use ATM was 85% of the respondents, while the rest were distributed among other means of banking, and the most important obstacles for the expansion of electronic banking were lack of security, confidentiality, and language.

While Fadeela (2009) held a study with the goal of identifying the impact of e-marketing on the quality of banking services and the most important means to do so. the study concluded that the Algerian banks used websites to identify themselves and branches, in addition to introducing its customers to its services, both electronic and traditional. It also concluded that there is an effect on electronic banking services quality by e-marketing, , and there are a number of risks represented by security and confidentiality.

Sowaidan (2009) Conducted a study entitled "The Impact of the word of mouth on the customer's purchasing decision in terms of choice and loyalty for the brand", aimed to determine the impact of the word of mouth on the decision purchasing decision for the consumer in terms of brand choice, the impact of communicating the word of mouth on consumer loyalty to the brand, and the different effect of communications of the word of mouth depending on demographic changes for consumers.

the researcher aimed to identify the Impact of the word of mouth on the customer's purchasing decision in terms of choice and loyalty for the brand, and whether there was a different effect of communications word of mouth depending on demographic changes for consumers.

The study found that there is a strong effect of the word of mouth from friends and relatives on the consumer's decision to buy, through the collection of adequate information before making a purchase decision, and that males are more affected by word of mouth than females are. Also noted the existence of differences in the impact of the word of mouth in different age groups , and the differences were in favor of the category (20-30 years).

The study recommended to business organizations the necessity to pay attention to word of mouth and place it within the promotional strategies due to its importance in the consumer choice of the brand and loyalty.

The study of Bashmav (2009) came and aimed to identify the relationship between quality and customer satisfaction in Jordanian banks, and the results indicate that there is no relationship between the dimensions of quality of banking services combined and customer satisfaction, but there is a relationship between each dimension of banking services quality independently and customer satisfaction.

Al-Akhdar (2010) also addressed a study to know the relationship between the modern concept of banking marketing and how far it relates to the development of banking services quality in Libyan commercial banks, where the results indicate the existence of significant differences between the application of the concept of modern marketing in Libyan commercial public and private banks with a percentage of 5%, and the existence of a direct correlation between the application of the concept of modern banking marketing and quality of Libyan commercial banking services.

Al-Janabi (2010) evaluated banking services via the Internet provided by the commercial banks of Jordan, and their impact on customers by measuring the ease of use of banking services via the Internet, the extent of diversity, level of education of the customers, the size of the risks, rewards, costs and the availability of protection for banking services provided through Internet as well as customer demand for them. The study found that the majority of Jordanian commercial banks have sites on the internet that provide information and offer banking services, all the banks are using methods of protection, and that the most influential factor is the ease of use, the degree of availability of confidentiality, safety, diversity of services and the size of the risks that customers can be exposed to.

Haddad and Jawdah (2011) conducted a study titled "e-marketing and its effect on banking services quality (a field study of Jordanian commercial banks)." the researchers aimed to study the extent to which Jordanian commercial banks clients perceive the concept and important of e-marketing, the role which e-marketing plays in enforcing the relationship between banks and their clients, the effect of e-marketing on the quality of banking services, the effect of demographic factors in understanding banking services quality, and contribute in providing a data base that can help the management of Jordanian commercial banks adopt the concept of e-marketing in dealing with the clients.

The study also concluded that there is a relationship: between the availability of a data base for marketing and the quality of banking services, between research and development and the quality of banking services, between safety and the quality of banking services, between marketing strategy and the quality of banking services, and that e-marketing has an impact on the quality of banking services, and that there are differences of statistical significance in the answers of the study sample on the quality of banking services that are attributed to demographical factors.

Mahamed and Al-Said (2012) Conducted a study entitled "The impact of the quality of e-business on the quality of banking services: a field study in banks operating in Jordan" aimed to assess the quality of e-business used in banks operating in Jordan from the perspective of workers in those banks, and the impact of the quality of the Electronic business used in banks operating in Jordan on the quality of banking services offered to global banks clients in Jordan, in addition to test whether there are statistically significant differences in the assessment of staff for the quality of e-business that are attributable to the demographics variables, such as sex, level of education, and number of years of experience.

The results of the study found that the quality of e-business used in banks operating in Jordan was at a high level, and that the banking services offered by banks operating in Jordan enjoy a high level of quality. In addition, there are no statistically significant differences in the assessment of staff for the quality e-business offered in banks attributable to demographic variables, such as sex, level of education, and number of years of experience. the results also showed that there were no statistically significant differences in the assessment of the quality of customer banking services provided by these banks. the study also found a lack of a statistically significant relationship between the quality of e-business used in banks operating in Jordan and the quality of banking services offered to clients by such banks.

Al-Aaraj (2013) conducted a study entitled "Factors influencing the choice of the type of services and outlet windows provided by electronic banks, analysis study of the views of dealers with Qatari banks." The goal of the researcher was to study the possibility of a discrepancy in the direction of members of the research sample of dealers with banks, according to the personal characteristics of each type of service and type of outlet that dealers favored with banks, study the existence of a relationship between the availability of capacity and knowledge using information technology of the dealers with the banks, and every type of service and type of outlet favored by dealers with banks, study the relationship between the availability of the means and tools of information technology to the clients and every type of service and type of window that dealers favored with banks, and study the variation in trends in dealing with the banks especially when turning to electronic banking brings many advantages.

The study found that personal characteristics of individuals, such as sex, age and level of education are one of the factors influencing the selection of the type of services and the outlet windows provided by the electronic banks (banking services) and that there is a discrepancy in the direction of members of the research sample dealing with banks attributed to those characteristics.

The study showed that knowledge of how to use information technology has a significant influence in the selection of the type of services and the outlet windows provided by electronic banking, and that there is an agreement in trends of clients that banks turning into electronic banking achieve the following benefits: customer satisfaction, punctual completion of banking services, reduction of the cost of banking service and achieving customer's trust and privacy , achieving accuracy, control and monitoring.

Ming and Sheih (2006) study aimed to look at the relationship between the quality of library services and user satisfaction in Taiwan and for this purpose, the performance of the service model was used. the study results have shown that there is a statistically significant relationship between the overall quality of service and user satisfaction, the results also show that the other dimensions of quality of the library service have had a positive impact on user satisfaction.

Tahir and Abu Bakar (2007) study aimed to assess the quality of banking services offered by commercial banks in Malaysia (east coast of Malaysia), as well as to assess the level of customer satisfaction reported, and for this purpose, the researchers used the quality of service model.

The results have shown that the quality of the services provided by these banks was less than the expectations of customers.

Regarding the importance of the dimensions of quality of service, customer attention came first while sympathy was the last. The results also show that customer satisfaction with the quality of services provided to them was weak.

Gouvêa and Masano (2008) study aimed to determine the best models to measure the quality of banking services offered by banks in the city of Sao Paulo (Brazil), and to highlight the relationship of the quality of service to both satisfaction and loyalty, and for this purpose each of the quality of service models has been used with or without weighting, and the performance of the service model.

The study results showed that among the models used, the measure of the performance of the service is the most appropriate model to measure the quality of service, and the results also showed the presence of a high correlation between the quality of service on the one hand, satisfaction and loyalty on the other.

### 3. Hypotheses of the Study

Based on the theoretical literature and referring to previous studies, the following assumptions have been developed:

Hypothesis Ho1: No statistically significant effect of word of mouth in the quality of banking services in the Jordanian commercial banks at the level of significance ( $\alpha \leq 0.05$ ).

Hypothesis Ho2: No statistically significant effect of the word of mouth in the adoption of electronic banking services in the Jordanian commercial banks at the level of significance ( $\alpha \leq 0.05$ ).

Hypothesis Ho3: No statistically significant effect of the word of mouth in the quality of banking services of Jordanian commercial banks in the presence of adoption of electronic banking services as an intermediary variable at the level of significance ( $\alpha \leq 0.05$ ).

### 4. Study Model

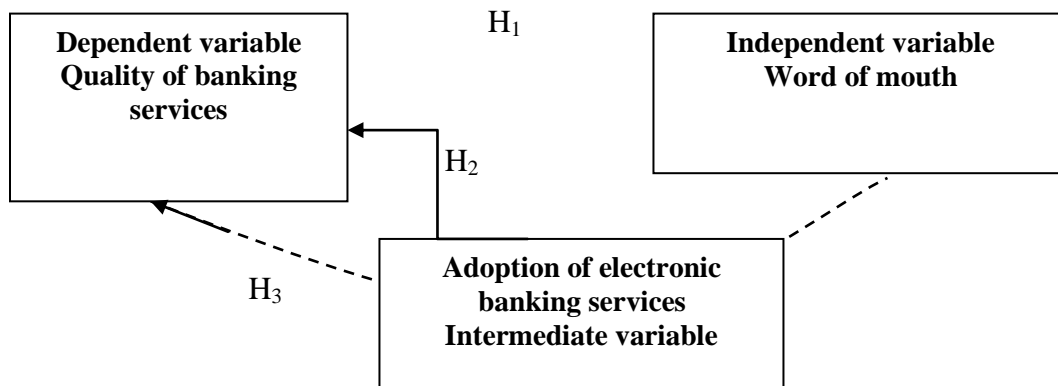

Diagram (1): Hypothetical Study

## 5. Study Methodology

### 5.1 Population of the Study

The study population consisted of all the customers who deal with commercial banks in Jordan's (12) commercial banks, and the study included clients of commercial banks in the capital, Amman.

Study sample: because the researchers were unable to provide a list of commercial banks clients from individuals, they have adopted an appropriate sample population (250) agents. the number of respondents was determined depending on the analysis of a random sample which consisted of (25) respondents, where the average standard deviation of their level of education was identified as (0.4807). Then the required sample size was calculated on the basis of the 90% confidence level and a tolerated error of 0.05 as follows:

Where: e : tolerated Error, S: Sample Standard Deviation, N: Required Sample Size

$$\text{Required Sample Size} = \frac{(0.407)^2 \times (1.645)^2}{(0.05)^2} = 280 \text{ individuals}$$

$$N = \frac{Z^2 s^2}{e^2}$$



(280) questionnaires Have been distributed evenly to customers in the commercial banks among the branches and centers in the capital, Amman, of which (270) filled questionnaires have been restored and 265 of them were found suitable for statistical analysis, which is an average of 98% of the total questionnaires recovered.

**5.2 Demographic characteristics of the study sample**

**Table 1: Questionnaire**

| Sequence  | Paragraphs  | Strongly agree | Agree | Neutral | Don't agree | Strongly disagree |
|---|---|----------------|-------|---------|-------------|-------------------|
| <b>Independent Variable-Word of Mouth</b>             |   |                |       |         |             |                   |
| 1.  | I seek advice from contacts when I decide to use electronic banking services.   |                |       |         |             |                   |
| 2.  | I appreciate the opinion of a contact as a source of advice and counsel on electronic banking services.                                   |                |       |         |             |                   |
| 3.  | I can think of at least two people of my contact who told me about electronic banking services.   |                |       |         |             |                   |
| 4.  | My humble experience about electronic banking services leads me to request information from a contact about that service.                 |                |       |         |             |                   |
| 5.  | I trust the information I get from a contact of more than the information I get from advertising means about electronic banking services. |                |       |         |             |                   |
| <b>Intermediate Variable</b>                          |   |                |       |         |             |                   |
| <b>1- Information data-base availability</b>          |   |                |       |         |             |                   |
| 6.  | Marketing brochures are sent to customers via the Internet.   |                |       |         |             |                   |
| 7.  | Bank has an accessible Website known to all its customers.  |                |       |         |             |                   |
| 8.  | Bank sends statements of accounts of customers through their e-mail?  |                |       |         |             |                   |
| <b>2- Punctuality of the service</b>                  |   |                |       |         |             |                   |
| 9.  | I can get the service that I want within the time that suits me.  |                |       |         |             |                   |
| 10.   | When the clients makes any inquiry through the Internet, the bank responds rapidly.   |                |       |         |             |                   |
| 11.   | My bank quickly delivers the services provided to its customers.  |                |       |         |             |                   |
| <b>3- Confidentiality and Safety</b>                  |   |                |       |         |             |                   |
| 12.   | I feel comfortable and reassured during my dealings with the bank through its website.  |                |       |         |             |                   |
| 13.   | I feel safe during my dealings with the bank on the World Wide Web.   |                |       |         |             |                   |
| <b>Dependent Variable-Quality of Banking Services</b> |   |                |       |         |             |                   |
| 14.   | my bank is characterized by working accurately and a lack of mistakes.  |                |       |         |             |                   |
| 15.   | Marketing through internet delivers required services properly.   |                |       |         |             |                   |
| 16.   | E-marketing services are available during times of vacations and holidays.  |                |       |         |             |                   |
| 17. 1   | I can rely on the bank's management in their quest to win customer satisfaction   |                |       |         |             |                   |
| 18. 1   | I feel that every employee in the bank knows the meaning of quality.  |                |       |         |             |                   |

Table shows (1) demographic variables of the inspection and analysis individuals (sex; age; experience duration; and education Qualification).Table (1) shows that 91% of the sampling and analysis individuals are males, and 9% are females.

Regarding the age variable, the results show that 12.5% of the sampling and analysis unit individuals are between the ages of 20 to 29 years old, and that 40% of the sampling and analysis unit individuals are between the ages of 30 to 39 years, and the results showed that 35.8 % of the sampling and analysis unit individuals are between the ages of 40 to 49 years. Finally, results show that the percentage of sampling and analysis unit individuals of those aged 50 years and older is a total of 11.7%.

As for the experience duration variable, the results showed that the rate of 49.8% of the sampling and analysis unit individuals are those whose number of practical experience years ranges from 5 to 10 years; and 7.6% are those who have practical experience of 5 years or less. Finally, it was found that the total percentage of respondents from the sampling and analysis unit individuals are those who have experience of more than 10 years was 42.6%. For the educational qualification variable, it has been shown that 5.7% are carriers of diploma or under, and that 72.8% of the sampling and analysis unit individuals have bachelor's degree in their specialty. Results also show that the percentage of individuals who hold a graduate degree certificate (MS or Ph.D.) in their field of specialty is 21.5%.

### **5.3 Procedural Definitions**

Word of mouth: a positive or negative feedback as a result of the service used by the customer or consumer, transferred to someone else (Lovelock and Wright, 2002).

Adoption of electronic banking services: customer shift towards the use of electronic banking services, the involvement of the customer with electronic banking services and using them in completing banking transactions.

Quality of banking services: a source which the client seeks to achieve the satisfaction of his needs and desires. the modern trends of banking marketing have given the customer particular importance as the client is the substrate on which to base a marketing system that is adopted by the bank. Moreover, the evaluation of the client's service and his judgment on the quality lies in the perceptions and expectations of the client (Mualla, 2007).

## **6. The tool of Gathering Information**

The researchers developed a questionnaire as a tool to collect data and information on the study, which consisted of four parts: the first part was devoted to describe the demographic variables of the study sample, and the second part included (5) paragraphs to measure the word of mouth, while the third part included (9) paragraphs to measure adoption of electronic banking services, spread over three dimensions, which are: (availability of information database, confidentiality and safety, punctuality in the performance of banking service), with three paragraphs for each dimension. Fourth part was designated to the quality of banking services measured through (5) paragraphs.

The Likert scale with the five degrees was adopted to evaluate the answers of respondents, the grade was calculated on the basis of giving 5 marks to the answer of “strongly agree”, (4) marks to the answer of “agree”, (3) marks to the answer of “neutral,” (2) marks for the answer of “don't not agree,” and one mark for the answer of “strongly disagree”. The second part of the questionnaire contained demographic information of the client, such as sex, age, length of experience, and level of education.

## **7. Questionnaire Reliability and Validity**

Apparent honesty: the questionnaire was shown to several arbitrators of university professors and some specialists in the field of banking marketing to study the accuracy of the wording and degree of relevance to the objectives of the study. The researchers reconsidered some of the phrases in the questionnaire in light of the amendments proposed by the arbitrators. To measure the accuracy of the results of the study, the (Cronbach Alpha) equation has been used where the alpha coefficient was (85.5%), which indicates the existence of a good consistency and coherence in the relationship between the questionnaire phrases, which is statistically acceptable (Sekaran, 2006).

Stability of the study tool: the internal consistency test (Cronbach's alpha), was used to measure the consistency in answering questions by the questionnaire respondents, and Table 1 shows the results of the tool stability for this study.

**Table 2: Indicates the Distribution of the Study Sample Individuals and the Appropriate Analysis According to Demographic Variables**

| Variable                  | Category                    | Repetition | Percentage % |
|---------------------------|-----------------------------|------------|--------------|
| Sex                       | Males                       | 241        | 91           |
|                           | Females                     | 24         | 9            |
| Total                     |                             | 265        | 100          |
| Age                       | 20-29 years                 | 33         | 12.5         |
|                           | 30-39 years                 | 106        | 40           |
|                           | 40-49years                  | 95         | 35.8         |
|                           | 50 years and older          | 31         | 11.7         |
| Total                     |                             | 265        | 100          |
| Experience duration       | Less than 5 years           | 20         | 7.6          |
|                           | 5-10 years                  | 132        | 49.8         |
|                           | More than 10 years          | 113        | 42.6         |
| Total                     |                             | 265        | 100          |
| Educational qualification | Diploma and under           | 15         | 5.7          |
|                           | Bachelor degree             | 193        | 72.8         |
|                           | Graduate school (MS or PhD) | 57         | 21.5         |
| Total                     |                             | 265        | 100          |

**Table 2: Questionnaire Internal Consistency Stability Variable (Cronbach Alpha $\alpha$ )**

| (t)   | variable   | Paragraph count | Alpha Value( $\alpha$ ) |
|-------|--|-----------------|-------------------------|
| 1     | Word of mouth                                      | 5               | 0.908                   |
| 2     | Quality of banking services                        | 9               | 0.925                   |
| 1 - 2 | Information database availability                  | 3               | 0.719                   |
| 2 - 2 | Confidentiality and safety                         | 3               | 0.840                   |
| 3 - 2 | Punctuality in the performance of banking services | 3               | 0.809                   |
| 3     | adoption of electronic banking services            | 5               | 0.821                   |

**Verification of the Suitability of the Data for Statistical Analysis**

For the purposes of verification of the objective results of the study, the Kolmogorov - Smirnov test has been conducted, in order to verify the absence of statistical problems from the study data, and problems that may adversely affect the results of the study hypotheses test. Such a test requires a normal distribution in the data. If not, then a correlation between independent and dependent variables of the study arises, and thus the correlation loses its ability to interpret or predict the phenomenon in question (Marsaglia et al., 2003): Table (3) illustrates this.

**Table 3: The Normal Distribution of the Study Variables Kolmogorov - Smirnov (KS)**

| t     | Variable   | Kolmogorov Smirnov | Sig.* | Result                      |
|-------|--|--------------------|-------|-----------------------------|
| 1     | Quality of banking services                        | 2.040              | 0.092 | Follows normal distribution |
| 1 - 1 | Information database availability                  | 1.487              | 0.056 | Follows normal distribution |
| 2 - 1 | Confidentiality and safety                         | 1.568              | 0.068 | Follows normal distribution |
| 3 - 1 | Punctuality in the performance of banking services | 1.593              | 0.079 | Follows normal distribution |
| 2     | Word of mouth                                      | 2.933              | 0.063 | Follows normal distribution |
| 3     | adoption of electronic banking services            | 2.987              | 0.116 | Follows normal distribution |

\* Distribution will be normal when the level of significance ( $\alpha \leq 0.05$ )

### 8. Analysis of the Study Data

To describe and analyze the variables of the study, the researchers resorted to the use of averages and standard deviations, as shown in the tables (4).

**Table 4: Averages and Standard Deviations for the Quality of Banking Services in the Jordanian Commercial Banks**

| (t) | Quality of banking services                        | Average | Standard deviation | Calculated (t) value | Sig* level of significance | level of quality |
|-----|--|---------|--------------------|----------------------|----------------------------|------------------|
| 1   | Information database availability                  | 3.867   | 0.831              | 16.999               | 0.000                      | High             |
| 2   | Confidentiality and safety                         | 3.909   | 0.834              | 17.742               | 0.000                      | High             |
| 3   | Punctuality in the performance of banking services | 3.758   | 0.867              | 14.238               | 0.000                      | High             |
|     | Quality of banking services                        | 3.845   | 0.829              | 15.197               | 0.000                      | High             |
|     | Word of mouth                                      | 3.482   | 0.696              | 11.163               | 0.000                      | Average          |
|     | adoption of electronic banking services            | 3.479   | 0.887              | 8.786                | 0.000                      | Average          |

Tabulated (t) Value at ( $\alpha \leq 0.05$ ) (1.96).

Word of mouth: averages and standard deviations were used, where the arithmetic average for the paragraphs of the word of mouth was (3.482) and standard deviation (0.6960) at the level of significance ( $\alpha = 0.000$ ), suggesting that the level of the word of mouth to the customers in the commercial banks in Jordan is average.

Quality of banking services: table (4) shows that the quality of banking services in the commercial banks in Jordan, from the standpoint of clients of these banks, was high, as the arithmetic average for the paragraphs of the word of mouth was (3.845) and standard deviation (0.8290) at the level of significance ( $\alpha = 0.000$ ), suggesting that the level of quality of banking services in the commercial banks in Jordan, from the point of view of the customer, is average.

Adoption of electronic banking services: to describe and analyze the adoption of electronic banking services in the commercial banks in Jordan, averages and standard deviations were used, where the arithmetic average of the quality of information was (3.479) and standard deviation (0.887) at the level of significance ( $\alpha = 0.000$ ), suggesting that the level of adoption of electronic banking services in the commercial banks in Jordan is average.

#### 8.1 Analysis of the Adequacy of the Data to the Test Assumptions of the Study Hypotheses

Before starting the regression analysis to test the hypotheses of the study, the researchers conducted some tests in order to ensure the adequacy of the data for the assumptions of the regression analysis, and it was confirmed that there is no high correlation between the independent variables "Multicollinearity" using the Variance Inflation Factor (VIF) and the tolerance variability test for each variable of the study variables taking into account not to exceed the variance tolerance (VIF) inflation factor (10), and that the value of the variation tolerance be greater than (0.05). Table (5) shows the results of these tests.

**Table (5) Results of the Variability Inflation Test and Variability Tolerance**

| (t) | Sub-independent variables               | VIF   | Tolerance |
|-----|---|-------|-----------|
| 1   | Word of mouth                           | 5.773 | 0.772     |
| 2   | Adoption of electronic banking services | 2.278 | 0.836     |

It is evident from the results listed in Table (5) that there is a lack of linear multi-Multicollinearity overlapping between independent variables, and it is confirmed by the values of the variation inflation factor test (VIF) for the variables of (the word of mouth, and the adoption of electronic banking services) which are (2.278; 5.773 respectively) and are less than (10). As can be seen, the values of the variance tolerance test (Tolerance) ranged between (0.836 -0.772) which is greater than (0.05) This is an indication of the lack of a high correlation between the independent variables.

## 9. Testing the Hypotheses of the Study

The first main hypothesis HO1

Hypothesis Ho1: No statistically significant effect of word of mouth in the quality of banking services in the Jordanian commercial banks at the level of significance ( $\alpha \leq 0.05$ ).

To test this hypothesis, the simple regression analysis has been used to check the impact of the word of mouth in the quality of banking services in the Jordanian commercial banks, as shown in table (6).

**Table (6) Results of the Simple Regression Analysis Test of the Impact of the Word of Mouth in the Quality of Banking Services**

| Dependent variable          | (R) correlation | (R <sup>2</sup> ) Coefficient of determination | F Calculated | DF Degrees of freedom | Sig* level of significance | $\beta$ Regression coefficient | T calculated | Sig* level of significance |
|-----------------------------|-----------------|--|--------------|-----------------------|----------------------------|--------------------------------|--------------|----------------------------|
| Quality of banking services | 0.640           | 0.410  | 225.097      | 1                     | 0.000                      | 0.574                          | 15.003       | 0.000                      |
|                             |                 |  |              | 263                   |                            |                                |              |                            |
|                             |                 |  |              | 264                   |                            |                                |              |                            |

\* The effect is statistically significant at the level of ( $\alpha \leq 0.05$ )

Table (6) shows the impact of the word of mouth on the quality of banking services in the Jordanian commercial banks. The statistical analysis results showed the presence of a statistically significant effect of the word of mouth on the quality of banking services in the Jordanian commercial banks, with a correlation coefficient R (0.640) at the level of ( $\alpha \leq 0.05$ ). The coefficient of determination R<sup>2</sup> reached (0.410), meaning that the value (0.410) of changes in the quality of banking services in the Jordanian commercial banks results from changes in the level of the word of mouth. The value of the degree of influence was  $\beta$  (0.574). This means that a one degree increase in the level of interest in the word of mouth leads to an increase in the quality of banking services in the Jordanian commercial banks. Such significance of the effect is confirmed by the F value calculated, which amounted to (225.097), which indicates at the level of ( $\alpha \leq 0.05$ ).

This debunks the first sub hypothesis, thus rejecting the first absolutist (zero) hypothesis, and accepting the alternative hypothesis, which states: The existence of statistically significant effect for the word of mouth in the quality of banking services in the Jordanian commercial banks at the level of significance ( $\alpha \leq 0.05$ ).

Hypothesis Ho2: No statistically significant effect of the word of mouth in the adoption of electronic banking services in the Jordanian commercial banks at the level of significance ( $\alpha \leq 0.05$ ).

To test this hypothesis, the simple regression analysis has been used to check the impact of the word of mouth in the adoption of electronic banking services in the Jordanian commercial banks, and as shown in the table (7).

**Table 7: Results of the Simple Regression Analysis Test of the Impact of the Word of Mouth in the Adoption of Electronic Banking Services**

| Dependent variable                      | (R) correlation | (R <sup>2</sup> ) Coefficient of determination | F Calculated | DF Degrees of freedom | Sig* level of significance | $\beta$ Regression coefficient | T calculated | Sig* level of significance |
|---|-----------------|--|--------------|-----------------------|----------------------------|--------------------------------|--------------|----------------------------|
| Adoption of electronic banking services | 0.580           | 0.336  | 164.318      | 1                     | 0.000                      | 0.531                          | 12.819       | 0.000                      |
|   |                 |  |              | 263                   |                            |                                |              |                            |
|   |                 |  |              | 264                   |                            |                                |              |                            |

Table (7) shows the impact of the word of mouth in the adoption of electronic banking services in the Jordanian commercial banks. The statistical analysis results showed the presence of a statistically significant effect where the correlation coefficient R was (0.580) at the level of ( $\alpha \leq 0.05$ ). The coefficient of determination R<sup>2</sup> reached (0.336), meaning that (0.336) of the changes in the electronic banking services result from the change in the level of the word of mouth. Also, the value of the degree of influence was  $\beta$  (0.531). This means that a one degree increase in the level of interest in the word of mouth leads to an increase in electronic banking services in the Jordanian commercial banks.

Such significance of the effect is confirmed by the F value calculated, which amounted to (164.318), which is indicated at the level of ( $\alpha \leq 0.05$ ).

This debunks the second sub hypothesis, thus rejecting the second absolutist (zero) hypothesis, and accepting the alternative hypothesis, which states: The existence of statistically significant effect for the word of mouth in the adoption of electronic banking services in the Jordanian commercial banks at the level of significance ( $\alpha \leq 0.05$ ). Hypothesis Ho3: No statistically significant effect of the word of mouth in the quality of banking services in the Jordanian commercial banks through the adoption of electronic banking services in the Jordanian commercial banks at the level of significance ( $\alpha \leq 0.05$ )

Path Analysis and the statistical program Amos V.21-backed by the Statistical Package for the Social Sciences program SPSS V.21 were used in order to verify if there is directly or indirectly an impact to the word of mouth in the quality of banking services in the Jordanian commercial banks through the adoption of electronic banking services as an intermediate variable, as shown in table (7), where the analysis results showed the presence of an effect of the word of mouth in the quality of banking services through the adoption of electronic banking services in the commercial banks of Jordan as an intermediate variable, as the calculated value of chi2 was (5.653) which is of significance when ( $\alpha \leq 0.05$ ). Also, the value of quality suitability index (GFI) Goodness of Fit Index was (0.995) and is near the value of the true one (perfect fit).

The Comparative Fit Index (CFI) reached (0.993), which is also near to the true one, in addition to the Root Mean Square Error of Approximation (RMSEA) having a value of (0.021), a value close to zero. Based on the statistical values mentioned, the direct impact of the word of mouth in the quality of banking services reached (0.692), and therefore, the increased attention to the word of mouth would affect the quality of banking services.

In the same direction, the direct effect of the adoption of electronic banking services in the quality of banking services reached (0.671), and therefore, the increased interest in the adoption of electronic banking services would generate an impact on the quality of banking services. The total indirect effect of the adoption of electronic banking services in the quality of banking services as an intermediate variable was (0.392), which emphasizes the role played by the adoption of electronic banking services in the promotion of the word of mouth. One of the indicators that reinforces this conclusion is the calculated T value of the coefficient of the first track effect (the word of mouth - the adoption of electronic banking services) which was (12.897), while the calculated T value of the coefficient of the second track effect (adoption electronic banking services - the quality of banking services) was (23.552), and this result indicates that the increased attention to the word of mouth, through the adoption of electronic banking services would have an impact on the quality of banking services, thus rejecting the (zero) hypothesis and accepting the alternative hypothesis.

**Table 8: Results of the Path Analysis of the Impact of the Word of Mouth in the Quality of Banking Services through the Adoption of Electronic Banking Services as an Intermediate Variable in the Jordanian Commercial Banks**

| Statement   | Chi <sup>2</sup><br>calculated | GF    | CFI   | RMSEA | Sig*<br>Level of<br>significance | Direct Effect<br>coefficient values |   | Indirect<br>Effect<br>coefficient<br>values | Track  | T<br>Calculated | Sig*<br>Level of<br>significance |
|---|--------------------------------|-------|-------|-------|----------------------------------|-------------------------------------|---|---|--------|-----------------|----------------------------------|
|   |                                |       |       |       |                                  | Word of<br>mouth                    | Adoption<br>of<br>electronic<br>banking<br>services |   |        |                 |                                  |
| Word of mouth<br>in the quality of<br>banking services<br>through the<br>quality of<br>banking services   | 5.653                          | 0.995 | 0.993 | 0.021 | 0.025                            | 0.692                               | 0.392   | WOM<br>↓<br>QSB                             | 12.897 | 0.00            |                                  |
|   |                                |       |       |       |                                  | 0.671                               |   | WOM<br>↓<br>AEBS                            |        |                 | 23.553                           |
| GFI : Goodness of Fit Index must Proximity to one<br>CFI : Comparative Fit Index must Proximity to one<br>0.05-0.08RMSEA : Root Mean Square Error of Approximation<br>Word of Mouth : WOM<br>AEBS :Adoption E-banking Services<br>QSB : Quality of services banks |                                |       |       |       |                                  |                                     |   |   |        |                 |                                  |

## 10. Results

1. The results indicated that the level of the word of mouth among customers who deal with commercial banks of Jordan was average, and the researchers believe that this result is logical since the word of mouth is a kind of behavioral trend between dealers, where this trend doesn't necessarily represent a critical guiding tool in the adoption of what is said or noted from the behavior of others, but it is a tool based on spontaneous sharing, where coordination of the flow of information is not intended between the dealers, nor is the seeding of ideas and applying them to bring the concept of cooperative network among dealers for benefits that may be shared. This of course requires a true partnership with clients and banks in addition to building strong relationships with customers by focusing on them, which leads to improve the effectiveness of the word of mouth.
2. The results indicated that the quality of banking services in the Jordanian commercial banks were high where confidentiality and safety came first, followed by the availability of information database, and in last place came punctuality in the performance of the banking service.
3. Study results indicated that the level of adoption of electronic banking services in the commercial banks in the Jordanian commercial banks from the standpoint of the study sample was average, and the researchers attribute this result to the fact that there is still concern by some customers of the operations of deposit or withdrawal, or even conducting other banking operations out of concern in dealing with financial transactions and liquidity itself.
4. The results showed that there is a statistically significant effect of the word of mouth in the quality of banking services in the Jordanian commercial banks at the level of significance ( $\alpha \leq 0.05$ ). and this effect is considered average from the viewpoint of researchers ( $R^2 = 0.41$ ), which means that there are other variables by a percentage of 59% that make a difference other than the word of mouth, and as a result, commercial banks could harness the word of mouth of its customers to support the provision of banking services quality and the adoption of electronic banking services therein.
5. There is a statistically significant effect for the word of mouth in the adoption of electronic banking services in the Jordanian commercial banks at the level of significance ( $\alpha \leq 0.05$ ), where the coefficient of determination ( $R^2 = 0.336$ ), a medium -impact from the perspective of the researchers, where there is a percentage of 66.% attributed to other factors that make a difference in the adoption of electronic banking services in the Jordanian commercial banks.
6. There is a statistically significant effect of the word of mouth in the quality of banking services through the adoption of electronic banking services as an intermediate variable in the Jordanian commercial banks at the level of significance ( $\alpha \leq 0.05$ ).

## 11. Recommendations

Based on the intellectual propositions for the study, analysis of the field results, and according to the results, the researchers offer the following recommendations:

1. Follow-up work on the technical developments in the field of electronic banking services and access to customers through the latest electronic means, having a direct impact on the quality of banking services.
2. Jordanian commercial banks should work to provide databases and marketing information to help customers meet their needs and assist them in making decisions regarding matters of banking.
3. Banks should work to create an atmosphere of trust, confidence, and security in their relations with customers.
4. Provide a variety of banking services due to its direct impact on the quality of banking services.
5. Banks should undertake studies and make use of the element of time to provide services as soon as possible, because speed and punctuality are linked with quality of the banking services.
6. Banks should take into account demographic factors of their customers in the marketing mix and the banking services.

## References

- Ab, Wahab, Norailis (2008) *Dimensions Of Service Quality And Service Climate: A Study Of Bank Customers And Employees in Four Local Malaysian Banks*. PhD Thesis, University of Sterling, Scotland.
- Adagunodo, E.; Awodele, O. and Ajayi, O. (2007) 'SMS banking Services, p10: A 21st Century Innovation', *Informing Science and Information Technology*, Vol. 4 No. 2, pp.17-32.

- Al-Aaraj, Mohammed Khalil (2013) *Factors influencing the choice of the type of services and windows provided by and electronic banking: an analytical study of the views of a sample of dealers with Qatari banks*. Unpublished Doctoral Dissertation, Open Academy in Denmark, Denmark.
- Al-Akhdar, Omar (2010) *The role of the modern concept of marketing in the development of the banking quality banking services*. Unpublished MA Thesis, University of Jordan.
- Al-Janabi, Hammad (2010) 'Evaluation of banking services via the Internet provided by the Jordanian commercial banks', *The Journal of Studies of Administrative Sciences*, Vol. 17 No. 4, pp. 78-102.
- Anuasi, F.I. and Toyo, P.A. (2009) 'Mobile Phone Technology in Banking System: It's Economic', *Research Journal of Information Technology*, Vol. 1 No. 1, pp. 1-5.
- Bashmav, Hadeel (2009) *The relationship between the dimensions of service quality and customer satisfaction in the Jordanian commercial banks*. Unpublished MA Thesis, University of Jordan.
- Cracknell, D. (2004) 'Electronic banking for the poor-panacea, potential and pitfalls', *Small Enterprise Development*, Vol. 15 No. 4, pp. 8-24.
- Davis, D. L., Guiltinan, J. G. and Jones, W.H. (1997) 'Service Characteristics, Consumer Research And The Classification Of Retail Services', *Journal Of Retailing*, Vol. 36 No. 3, pp. 421-447.
- Delhi-Hyderabad-London (2007) 'Mobile banking – the future', *Journal of marketing*, Vol. 12 No. 5, pp 112-122.
- Fadeelah, Chirouf (2009) *The impact of e-marketing on the quality of banking services*. Unpublished MA Thesis, University Mentouri Constantine Algeria.
- Gouvêa, Maria Aparecida and RaduanMasano, Ana Carolina (2008) 'Satisfaction and Loyalty of Bank Clients in the Municipality of São Paulo- Brazil', *POMS 19th Annual Conference*, La Jolla, California, U.S.A., 008-0576. Accessed on: 15/3/2014, Available at: <http://ebiz.uoregon.edu/poms2008/FullPapers/008-0576.pdf>.
- Haddad, Shafiq and Jawdah, Mahfouz (2011) *E-marketing and its impact on the quality of banking services: a field study on the Jordanian commercial banks*.the University of Applied Sciences, Amman, Jordan.
- Ivatury, G. & Mas, I. (2008) *The early experience with branchless banking*, Washington DC: CGAP.
- Kolodinsky, J., Hogarth, J. M., &Shue, J. F. (2004) 'The Adoption of Electronic Banking Technologies by American Consumers', *Consumer Interests Annual*, Vol. 47 No. 47, pp. 1-6.
- Lee, H. and Young , S. (2009) 'Formation of e-satisfaction and repurchase intention: Moderating roles of computer self efficacy and computer anxiety', *Expert Systems with Applications*, Vo. 36: pp.7848-7859.
- Lovelock, Christopher and Wright, Lauren (2002) *Principles Of Service Marketing And Management*, 2<sup>nd</sup> ed., Prentice Hall.
- Mahamed, Asaud and Al-Said, Moataz (2012) 'The impact of the quality of e-business on the quality of banking services: A field Study of the banks operating in Jordan', *Journal of Information Studies*, No. XIII.
- Ming, Wang and Sheih, Chich-Jen (2006) 'The Relationship Between Service Quality and Satisfaction', *Journal of Information and Optimization Sciences*, Vol. 27 No. 1, pp. 193-209. Accessed on: 19/2/2014, Available at: <http://www.tarupublications.com/journals/jios/full-text/JIOS-27-1-2006/jios134.pdf>.
- Money, R. BruceMilly, Mary C. and Graham, John L. (1998) 'Explorations Of National Culture And Word – OfMouth Referral Behavior In The Purchase Of Industrial Services In The United State And Japan', *Journal Of Marketing*, Vol (62) No4, pp.76-87.
- Murray, K.B. (1991) 'A Test Of Services Marketing Theory: Consumer Information Acquisition Activities', *Journal Of Marketing*, Vol. 55 No. 1, pp.10-25.
- Parasuraman, Berry and Zeithaml(1991) 'Perceived Service Quality as a Customer-BasedPerformance Measure: An Empirical Examination of Organizational Barriers Using anExtended Service Quality Model', *Human Resource Management*, Vol.30 No.3, pp.335-364.
- Parasuraman, Zeithaml and Berry (1985) 'A Conceptual Model of Service Quality and Its Implications for Future Research', *Journal of Marketing*, Vol.49 No.1, pp. 41-50.
- Sowaidan, Netham (2009) 'The impact of the word of mouth on the customer purchasing decision in terms of choice and loyalty for the brand', *the Seventh International Conference of the Faculty of Economics and Administrative Sciences: Implications of the global economic crisis on business organizations challenges, opportunities*, prospects for the period 3-5 November 2009 Zarqa Private University, Zarqa, Jordan.
- Tahir, IzahMohd and Abu Bakar, Mazlina Nor (2007) 'Service Quality Gap Between Customers' Satisfactions of Commercial Banks of Malaysia', *International Review of Business Research Papers*, Vol. 3 No. 4, pp.327-336. Accessed on: 15/2/2014, Available at: <http://www.bizresearchpapers.com/Tahir.pdf>.
- Trolle, A.B. and Schwartz, E.S. (2010) 'Variance risk premia in commodity markets', *Journal of Derivatives*, Vol. 17 No. 3, pp. 15-32.
- Zeithmal, Valarie A. Bitner, Mary Jo and Gremler, Dwayne D. (2006) *Services Marketing*, 6<sup>th</sup> ed., McGraw Hill.